



# GRIPSAFE<sup>®</sup> ST

## OPERATING MANUAL



---

### Small Inboard Insertion Blocking (IIB) Plug

$\frac{3}{4}$ " – 4"\*

\*For 4" Schedules 120, 160 and XXH only. Additional 4" Schedules Require the GripSafe ST Large IIB Plug

---

Manufactured Exclusively by USA Industries, an  
ISO 9001:2015 Certified Company

For patent and trademark information, go to  
<https://www.USAIindustries.com/gripsafe-patents/trademarks/>

**[www.USAIindustries.com](http://www.USAIindustries.com)**  
**(713) 941-3797 • (800) 456-8721**  
315 State Street • S. Houston, TX 77587

## Table of Contents

---



1. Introduction .....	1
2. Safety.....	2
3. Parts .....	3
4. Specifications .....	6
5. Preparing the GripSafe ST IIB Plug for Installation.....	8
6. Installing the GripSafe ST IIB Plug .....	9
7. GripSafe ST IIB Plug Removal .....	12

## 1. Introduction

---

Thank you for choosing GripSafe ST pipe plugging technology. This manual covers the proper use of this technology to ensure safe operating conditions. All necessary sockets and wrenches to install this equipment are available for rental/purchase from USA Industries, LLC. See **Section 4 Table 2** for sockets.

The information in this manual is intended for the use of a GripSafe ST IIB plug in metallic piping. If the intended use of this plug is for any piping other than metallic piping please contact USA Industries Customer Service Department for technical support.

-  Do not use GripSafe ST equipment before fully reading and comprehending and comprehending this manual
-  Failure to follow this manual in full may result in injury to personnel and damage to equipment.

## 2. Safety

---

- ⚠ Failure to follow proper safety requirements may result in the GripSafe ST IIB plug failing, which could lead to personnel injury, material loss, and damage to equipment.
- ⚠ Wear proper PPE when performing any task with the GripSafe ST IIB plug as defined by site safety rules. Always follow site procedure for safely lifting and operating equipment.
- ⚠ Never install the GripSafe ST IIB plug in a position where the Gripping Wedge would be located over weld droop or ridge.
- ⚠ Never install the Seals or Gripping Wedge over a section of pipe that is missing its interior wall; e.g. weldolet, tee, etc.
- ⚠ Use care in the handling of the Wedge Studs. Never beat, hammer, or pry on the Wedge Studs. Never remove the nut located on the Wedge Studs.
- ⚠ Pressure testing can be an extremely hazardous operation and safety precautions should be strictly adhered to. Never stand or pass in front of any test plug while installed or while testing is in progress.
- ⚠ Do not make any adjustment to the plug, safety equipment, or vessel while the plug is under pressure.
- ⚠ Do not exceed rated pressure stamped on the plug. Plugs are rated for holding pressure in one direction only, never apply pressure on the non-rated side of the plug.
- ⚠ Backpressure rating on the plug is in reference to the plugs ultimate holding capacity. Never exceed the pressure capacity of the weakest component in a pressurized system. It is imperative that a system's components be studied prior to beginning a pressure test to confirm the maximum test pressure a system can be subjected to in accordance with all applicable industry and site-specific standards.
- ⚠ It is recommended that water be used as the test medium. Venting all gases from the vessel being pressurized is necessary before pressurizing the system.
- ⚠ In the event pneumatic testing is required, all attempts to limit potential damage to any personnel or equipment must be made. USA Industries recommends Nitrogen as the medium for pneumatic testing as it does not support combustion. Follow provisions outlined in ASME PCC-2 Repair of Pressure Equipment and Piping when testing pneumatically.
- ⚠ Careful observation is needed at the location of the pipe where the Wedge Grippers make contact while performing a hydrotest. If any deformation or swelling of the pipe is observed, stop immediately and slowly release the pressure from the system. Contact USA Industries for further assistance.
- ⚠ At any time during hydrotesting, if a popping or clicking sound is heard, stop immediately and slowly release the pressure from the system. Popping or clicking sounds during hydrotesting could be a sign of the Wedge Gripper slipping, cracking, or plug components failing. Remove the plug from the pipe or fitting and inspect for damage. Contact USA Industries for further assistance.
- ⚠ The GripSafe ST IIB plug is designed to hold pressure originating from the installation side only.
- ⚠ Ensure plug is clean of debris, fouling, and contaminants before each use. Each Wedge Grippers should freely slide up and down in its slots with a full range of motion without any resistance. With impeded movement due to debris, dirt, contaminants, or other fouling will cause the plug to not grip on the pipe's inner diameter, which can cause it to eject under pressure, leading to personnel injury or death, material loss, and damage to equipment.
- ⚠ For any questions or concerns, contact USA Industries for technical assistance.

### 3. Parts

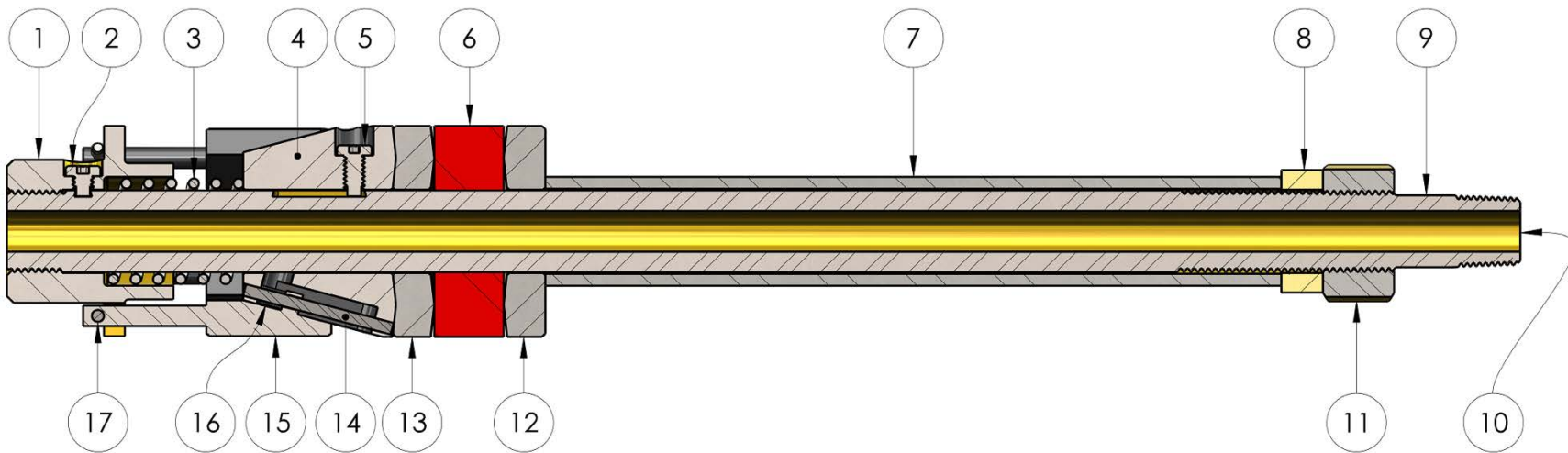

Figure 1: GripSafe ST Inboard Insertion Blocking 3/4" – 2" (IIB) Diagram

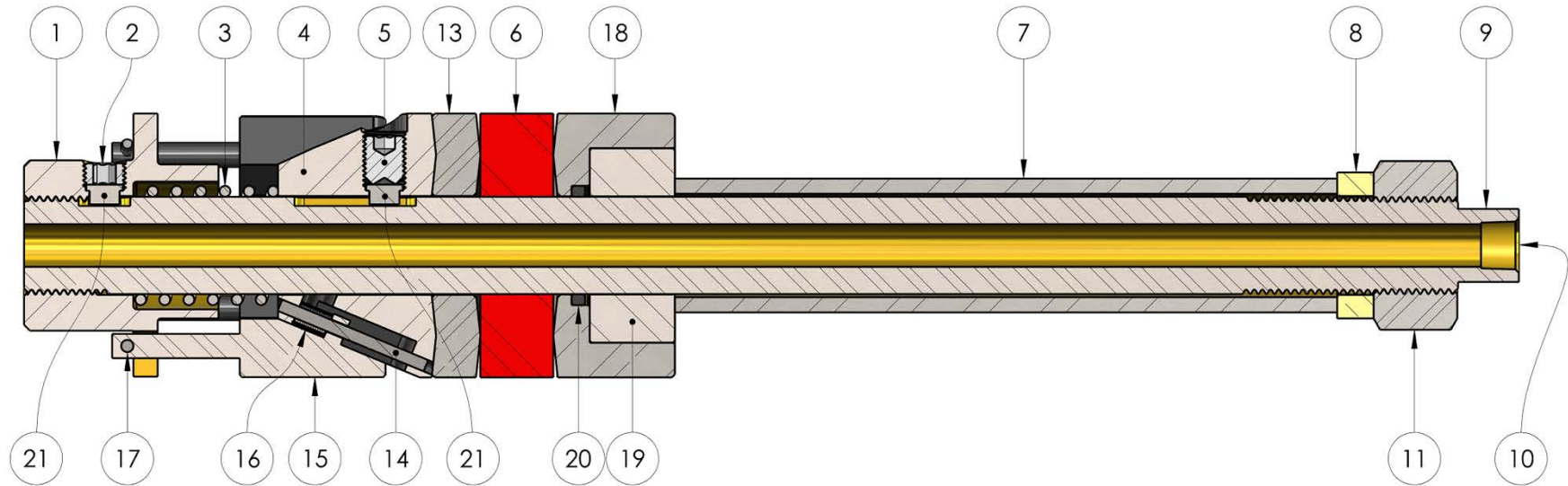

Figure 2: GripSafe ST Inboard Insertion Blocking 2-1/2" – 4" (IIB) Diagram

**Table 1: GripSafe ST IIB Plug Bill Of Materials**

Nominal Pipe Size (in)	Schedule	(1) IIB Spring Plate	(2) Spring Plate Alignment Screw	(3) Retraction Spring	(4) Wedge Cone	(5) Wedge Cone Alignment Screw	(6) Seal	(7) IIB Compression Tubing	(8) Thrust Bearing	(9) Shaft	(10) Vent Port	(11) Compression Hex Nut	(12) IIB Bottom Compression Plate	(13) IIB Top Compression Plate	(14) Wedge Gripper Retaining Dowel Pin	(15) Wedge Gripper	(16) Wedge Gripper Spring	(17) Wedge Gripper Stem Dowel Pin	(18) Sealing Compression Ring	(19) O-Ring Compression Insert	(20) Compression Ring O-Ring	(21) Spring Plate and Wedge Cone Alignment Key
3/4	40,STD,40S	1	0	1	1	1	1	1	1	1	1	1	1	0	5	5	5	5	0	0	0	0
	80,XS,80S	1	0	1	1	1	1	1	1	1	1	1	1	0	5	5	5	5	0	0	0	0
1	10	1	0	1	1	1	1	1	1	1	1	1	1	0	6	6	6	6	0	0	0	0
	40,STD,40S	1	0	1	1	1	1	1	1	1	1	1	1	0	5	5	5	5	0	0	0	0
	80,XS,80S	1	0	1	1	1	1	1	1	1	1	1	1	0	5	5	5	5	0	0	0	0
	160	1	0	1	1	1	1	1	1	1	1	1	1	0	5	5	5	5	0	0	0	0
1-1/4	10	1	1	1	1	1	1	1	1	1	1	1	1	0	7	7	7	7	0	0	0	0
	40,STD,40S	1	1	1	1	1	1	1	1	1	1	1	1	0	6	6	6	6	0	0	0	0
	80,XS,80S	1	1	1	1	1	1	1	1	1	1	1	1	0	5	5	5	5	0	0	0	0
	160	1	0	1	1	1	1	1	1	1	1	1	1	0	6	6	6	6	0	0	0	0
1-1/2	XX	1	0	1	1	1	1	1	1	1	1	1	1	0	6	6	6	6	0	0	0	0
	10	1	1	1	1	1	1	1	1	1	1	1	1	0	7	7	7	7	0	0	0	0
	40,STD,40S	1	1	1	1	1	1	1	1	1	1	1	1	0	6	6	6	6	0	0	0	0
	80,XS,80S	1	1	1	1	1	1	1	1	1	1	1	1	0	5	5	5	5	0	0	0	0
2	160	1	1	1	1	1	1	1	1	1	1	1	1	0	6	6	6	6	0	0	0	0
	XX	1	0	1	1	1	1	1	1	1	1	1	1	0	6	6	6	6	0	0	0	0
	10	1	1	1	1	1	1	1	1	1	1	1	1	1	7	7	7	7	0	0	0	0
	40,STD,40S	1	1	1	1	1	1	1	1	1	1	1	1	1	6	6	6	6	0	0	0	0
2-1/2	80,XS,80S	1	1	1	1	1	1	1	1	1	1	1	1	1	6	6	6	6	0	0	0	0
	160	1	1	1	1	1	1	1	1	1	1	1	1	1	7	7	7	7	0	0	0	0
	XX	1	1	1	1	1	1	1	1	1	1	1	1	0	7	7	7	7	0	0	0	0
	10	1	1	1	1	1	1	1	1	1	1	1	1	1	8	8	8	8	1	1	1	2
3	40,STD,40S	1	1	1	1	1	1	1	1	1	1	1	1	1	7	7	7	7	1	1	1	2
	80,XS,80S	1	1	1	1	1	1	1	1	1	1	1	1	1	7	7	7	7	1	1	1	2
	160	1	1	1	1	1	1	1	1	1	1	1	1	1	7	7	7	7	1	1	1	2
	XX	1	1	1	1	1	1	1	1	1	1	1	1	1	7	7	7	7	1	1	1	2
3-1/2	10	1	1	1	1	1	1	1	1	1	1	1	1	1	8	8	8	8	1	1	1	2
	40,STD,40S	1	1	1	1	1	1	1	1	1	1	1	1	1	7	7	7	7	1	1	1	2
	80,XS,80S	1	1	1	1	1	1	1	1	1	1	1	1	1	7	7	7	7	1	1	1	2
	XX	1	1	1	1	1	1	1	1	1	1	1	1	1	6	6	6	6	1	1	1	2
4	120	1	1	1	1	1	1	1	1	1	1	1	1	1	7	7	7	7	1	1	1	2
	160	1	1	1	1	1	1	1	1	1	1	1	1	1	7	7	7	7	1	1	1	2
	XX	1	1	1	1	1	1	1	1	1	1	1	1	1	7	7	7	7	1	1	1	2

## 4. Specifications

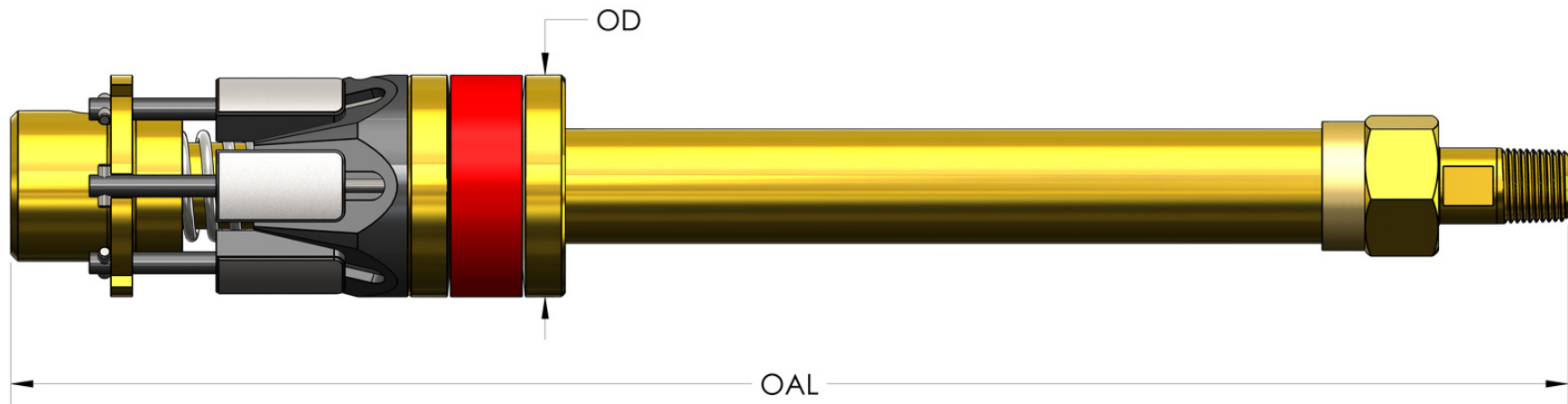

Figure 3: GripSafe ST Inboard Insertion Blocking (IIB) Plug Diagram Dimensions





**Table 2: GripSafe ST IIB Plug Specifications**

Nominal Pipe Size (in)	Schedule	Part Number	Tool Diameter (in)	Rec. ID Range* (in)	Nominal Pipe ID Clearance (in)	Approx. Tool Weight (lbs)	Tool Length (in)	Torque Range (ft-lbs)		Compression Hex Nut Socket Size (in)	Backup Wrench Size (in)	Back Pressure Vent Thread	Test Pressure Rating (PSI)*
								Norm	Max.				
3/4	40,STD,40S	GSST-I-R-0075-040	0.79	0.80 - 0.87	0.035	0.6	8.69	2.9	4.5	1/2	1/4 Open End	1/4 MNPT	10000
	80,XS,80S	GSST-I-R-0075-080	0.71	0.72 - 0.79	0.035	0.6	8.69	2.2	3.5	1/2	1/4 Open End	1/4 MNPT	10000
1	10	GSST-I-R-0100-010	1.04	1.06 - 1.16	0.055	0.8	9.19	6.3	9.7	9/16	1/4 Open End	1/16 MNPT	10000
	40,STD,40S	GSST-I-R-0100-040	0.99	1.02 - 1.11	0.055	0.8	9.19	5.6	8.7	9/16	1/4 Open End	1/16 MNPT	10000
	80,XS,80S	GSST-I-R-0100-080	0.90	0.92 - 1.02	0.055	0.8	9.19	4.5	6.9	9/16	1/4 Open End	1/16 MNPT	10000
	160	GSST-I-R-0100-160	0.78	0.79 - 0.85	0.035	0.6	8.69	2.8	4.4	1/2	1/4 Open End	1/4 MNPT	10000
	10	GSST-I-R-0125-010	1.38	1.39 - 1.54	0.068	1.9	12.19	15	23	3/4	3/8 Open End	1/8 MNPT	10000
1-1/4	40,STD,40S	GSST-I-R-0125-040	1.31	1.33 - 1.48	0.068	1.9	12.19	13	20	3/4	3/8 Open End	1/8 MNPT	10000
	80,XS,80S	GSST-I-R-0125-080	1.21	1.23 - 1.38	0.065	1.8	12.19	11	17	3/4	3/8 Open End	1/8 MNPT	10000
	160	GSST-I-R-0125-160	1.11	1.12 - 1.22	0.055	0.9	9.19	7.2	11	9/16	1/4 Open End	1/16 MNPT	10000
	XX	GSST-I-R-0125-XX	0.86	0.87 - 0.94	0.045	0.6	8.69	3.5	5.5	1/2	1/4 Open End	1/4 MNPT	10000
1-1/2	10	GSST-I-R-0150-010	1.60	1.64 - 1.80	0.085	2.4	12.63	24	37	15/16	7/16 Open End	1/4 MNPT	10000
	40,STD,40S	GSST-I-R-0150-040	1.53	1.56 - 1.73	0.085	2.3	12.63	21	33	15/16	7/16 Open End	1/4 MNPT	10000
	80,XS,80S	GSST-I-R-0150-080	1.42	1.45 - 1.62	0.085	2.1	12.63	18	28	15/16	7/16 Open End	1/4 MNPT	10000
	160	GSST-I-R-0150-160	1.27	1.30 - 1.44	0.068	1.8	12.19	12	19	3/4	3/8 Open End	1/8 MNPT	10000
	XX	GSST-I-R-0150-XX	1.05	1.08 - 1.16	0.055	0.8	9.19	6.3	9.8	9/16	1/4 Open End	1/16 MNPT	10000
2	10	GSST-I-R-0200-010	2.03	2.05 - 2.28	0.130	4.0	13.63	47	75	1-1/8	9/16 Open End	3/8 MNPT	10000
	40,STD,40S	GSST-I-R-0200-040	1.94	1.97 - 2.19	0.130	3.8	13.63	42	65	1-1/8	9/16 Open End	3/8 MNPT	10000
	80,XS,80S	GSST-I-R-0200-080	1.81	1.84 - 2.06	0.130	3.5	13.63	36	55	1-1/8	9/16 Open End	3/8 MNPT	10000
	160	GSST-I-R-0200-160	1.60	1.64 - 1.80	0.085	2.4	12.63	24	37	15/16	7/16 Open End	1/4 MNPT	10000
	XX	GSST-I-R-0200-XX	1.42	1.45 - 1.62	0.085	2.2	12.63	18	28	15/16	7/16 Open End	1/4 MNPT	10000
2-1/2	10	GSST-I-R-0250-010	2.51	2.57 - 2.77	0.125	7.2	15.38	85	135	1-5/16	9/16 Open End	3/8 MNPT	8000
	40,STD,40S	GSST-I-R-0250-040	2.34	2.38 - 2.61	0.125	6.6	15.38	75	115	1-5/16	9/16 Open End	3/8 MNPT	8000
	80,XS,80S	GSST-I-R-0250-080	2.20	2.24 - 2.46	0.125	6.2	15.38	65	100	1-5/16	9/16 Open End	3/8 MNPT	8000
	160	GSST-I-R-0250-160	2.00	2.06 - 2.25	0.125	3.9	13.63	46	70	1-1/8	9/16 Open End	3/8 MNPT	10000
	XX	GSST-I-R-0250-XX	1.69	1.74 - 1.89	0.085	2.5	12.63	27	42	15/16	7/16 Open End	1/4 MNPT	10000
3	10	GSST-I-R-0300-010	3.07	3.10 - 3.44	0.193	9.1	15.38	150	230	1-1/2	3/4 Box End	1/4 FNPT	8000
	40,STD,40S	GSST-I-R-0300-040	2.88	2.92 - 3.25	0.193	9.7	15.38	130	200	1-1/2	3/4 Box End	1/4 FNPT	8000
	80,XS,80S	GSST-I-R-0300-080	2.71	2.75 - 3.09	0.190	9.0	15.38	110	175	1-1/2	3/4 Box End	1/4 FNPT	8000
	160	GSST-I-R-0300-160	2.50	2.56 - 2.76	0.125	6.1	15.38	85	130	1-5/16	9/16 Open End	3/8 MNPT	8000
	XX	GSST-I-R-0300-XX	2.18	2.24 - 2.42	0.125	6.1	13.63	55	85	1-1/8	9/16 Open End	3/8 MNPT	8000
3-1/2	10	GSST-I-R-0350-010	3.56	3.61 - 3.96	0.204	11.1	15.38	225	350	1-11/16	7/8 Box End	3/8 FNPT	6000
	40,STD,40S	GSST-I-R-0350-040	3.34	3.39 - 3.75	0.204	13.4	15.38	195	305	1-11/16	7/8 Box End	3/8 FNPT	6000
	80,XS,80S	GSST-I-R-0350-080	3.16	3.21 - 3.56	0.208	12.3	15.38	175	270	1-11/16	7/8 Box End	3/8 FNPT	6000
	XX	GSST-I-R-0350-XX	2.60	2.66 - 2.86	0.125	7.5	15.38	95	145	1-5/16	9/16 Open End	3/8 MNPT	8000
4	120	GSST-I-R-0400-120	3.42	3.52 - 3.83	0.205	10.5	15.38	205	320	1-11/16	7/8 Box End	3/8 FNPT	6000
	160	GSST-I-R-0400-160	3.23	3.33 - 3.64	0.205	9.7	15.38	185	285	1-11/16	7/8 Box End	3/8 FNPT	6000
	XX	GSST-I-R-0400-XX	2.96	2.99 - 3.34	0.193	8.6	15.38	135	215	1-1/2	3/4 Box End	1/4 FNPT	8000





## 5. Preparing the GripSafe ST IIB Plug for Installation

- The GripSafe ST IIB plug should be in the “Ready to Install” position from the factory.



Figure 4: Ready to Install (Retracted)



Figure 5: Not Ready to Install (Compressed)

- Ensure the **Compression Hex Nut(11)** is loose and the GripSafe ST IIB plug is in the Retracted (Ready to Install) state as shown in Figure 4.
- In the Compressed (Not Ready to Install) state, shown in Figure 5, the GripSafe IIB plug’s **Wedge Grippers(15)** will obstruct insertion into the pipe.
- In the Retracted state, shown in Figure 4, the GripSafe ST IIB plug will not immediately grip the pipe upon insertion.
- If the plug is being used for pressure testing, install a cap or plug on **Vent Port(10)** to seal the system.



**CHECK:** Ensure plug is clean of debris, fouling, and contaminants before each use. Each **Wedge Gripper(15)** should slide freely up and down in its slot with a full range of motion and without resistance. **Wedge Gripper(15)** with impeded movement due to debris, dirt, contaminants or other fouling will cause the plug to not grip on the pipe’s inner diameter, which can cause the plug to eject under pressure, leading to personnel injury or death, material loss, and damage to equipment.



**NOTE:** To check IIB **Wedge Gripper’s(15)** freedom of movement, the **Compression Hex Nut(11)** have to be tightened first to the point where the **IIB Spring Plate(1)** is in the Compressed state, see Figure 4, and is flushed with the **Wedge Cone(4)**. After checking for **Wedge Gripper’s(3)** freedom of movement, loosen the **Compression Hex Nut(11)** so that the plug is in the Retracted state before installation.

## 6. Installing the GripSafe ST IIB Plug



**CAUTION:** Ensure pipe I.D. is clean. Debris, pipe scaling, and rust layer must be removed to the deepest point the plug will be installed into. If the pipe is lined or has irremovable product, **STOP** and contact USA Industries for support before proceeding. Failure to do so may impede the wedge's ability to grip and cause the plug to eject under pressure. Be sure to wear proper PPE **and follow all site guidelines.**

### 6.1. Insert the GripSafe ST IIB plug into the pipe or fitting.

- See Table 2 for Operational ID Range and clearance.
- Insert the GripSafe ST IIB plug into the pipe, **Wedge Gripper(15)** side first, see Figure 6.
- When testing a weld neck flange weld, the **IIB Bottom Compression Plate(12)** for sizes ¾” – 2” or the **Sealing Compression Ring(18)** for sizes 2.5” – 4.00” must be inserted past the weld droop and “DIM A”, shown in Figure 6, cannot be longer than the “Bore Depth Per Flange Class” listed on Table 3. Measurements larger than specified values from “DIM A” will interfere with the installation of the test flange.

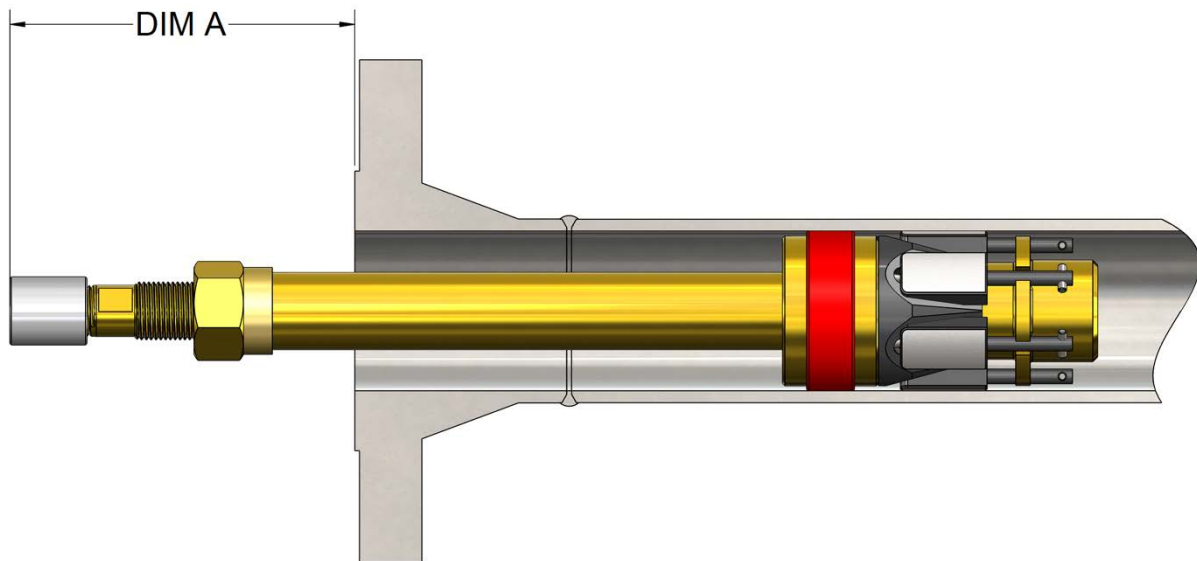

Figure 6: GripSafe ST IIB Depth Insertion

**Table 3: GripSafe ST IIB Plug Flange Bore Depth**

NPS	Bore Depth Per Flange Class						
	#150	#300	#400	#600	#900	#1500	#2500
3/4	2.94	3.13	3.19	3.19	3.69	3.69	CUSTOM
1	3.13	3.38	3.44	3.44	3.88	3.88	CUSTOM
1-1/4	3.59	3.9	4.02	4.02	4.28	4.31	CUSTOM
1-1/2	3.71	3.96	4.08	4.08	4.58	4.61	CUSTOM
2	3.88	4.13	4.32	4.32	5.44	CUSTOM	CUSTOM
2-1/2	4.26	4.51	4.69	4.69	5.69	CUSTOM	CUSTOM
3	4.08	4.45	4.64	4.64	5.39	CUSTOM	CUSTOM
3-1/2	4.25	4.63	4.88	4.88	N/A	N/A	N/A
4	4.29	4.67	4.85	5.35	5.79	CUSTOM	CUSTOM



**CAUTION:** GripSafe ST IIB is designed to hold pressure originating from the installation side only. If pressure is anticipated on the other side of the plug, contact USA Industries for possible solution, see Figure 7. Disregarding this caution may result in the GripSafe ST Plug ejecting, which could lead to personnel injury, material loss, and damage.



**CAUTION:** In the Retracted state, it is important to note the plug will not be immediately gripping the pipe upon insertion. Only after tightening the **Compression Hex Nut(11)**, while plug is in the pipe, to advance the bottom of the **IIB Spring Plate(1)** to contact the **Wedge Cone(4)**, will the plug be securely gripping the pipe.



**TEMPERATURE NOTE:** If welding is to occur on the pipe while the plug is installed, the **Seal(6)** should be installed a minimum of 6” from the center of an active weld to prevent it from degrading or ultimately failing due to melting. For post weld heat treats, bake-outs, etc., the **Seal(6)** should be at least 12” from the nearest edge of the heating element, and the temperature at the depth the plug is installed at should not exceed 220° F. If a high temperature bake out is being performed (400° F or higher) increase the installation depth as much as possible.

6.2. Tighten the **Compression Hex Nut(11)**

- Use a crow’s foot attached to a torque wrench to turn the **Compression Hex Nut(11)** while holding the Backup Hex or flats on the **Shaft(9)** stationary with a box end wrench.
- Continue tightening until the Minimum Compression Torque (Table 2) is reached.



**CAUTION:** Using an impact wrench is not recommended as it can damage both the **Spring Plate Alignment Screw(2)** and **Wedge Cone Alignment Screw(5)** for sizes 3/4" – 2" or **Spring Plate and Wedge Cone Alignment Key(21)** for sizes 2-1/2" and above.



**CAUTION:** Failure to use a backup wrench to keep the shaft stationary will place excessive stress on the **Wedge Cone Alignment Screw(5)** for sizes 3/4" – 2", or **Spring Plate and Wedge Cone Alignment Key(21)** for sizes 2-1/2" and above, which could cause failure, resulting in a stuck plug and/or cause it to eject under pressure.

### 6.3. Install Gasket and IIB Blind Flange

- Use in house procedures to install the appropriate gasket and IIB Flange for the application.
- Follow gasket manufacturer's torque and installation procedure or use an approved in house procedure.

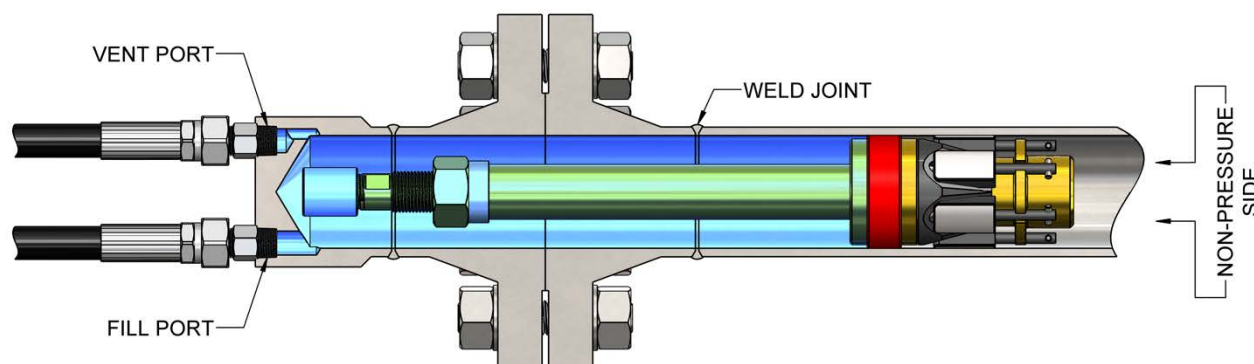

Figure 7: GripSafe Weld Neck Flange Hydrotesting

- 6.4. Attach the hydro pump's hose to the NPT Fill Port of the Flange.
- 6.5. Bleed off air by pumping water into the system while keeping the NPT Vent Port Open.
- 6.6. Once air has been purged, plug or attach a hose to the NPT Vent Port.
- 6.7. Pressurize system through the Flange ports and verify the integrity of the Seal.
  - Increase pressure to 20% of target pressure or 100 psig, whichever is less. Observance of pressure drop may not be an indication of leakage. USA Industries' **Seals(6)** will creep under pressure until they are fully seated. This creep will increase the pressure test volume. Depending on the test volume size this may be by such a trivial amount it will not be seen on a gauge. For relatively small test volumes a noticeable gradual loss in pressure may be observed during this creep phase. Seating the seal is obtained by reapplying pressure until the pressure becomes stable. This seal creep may also be observed when the system is subjected to the full pressure. Resolution to the creep is the same at high pressure and while verifying integrity.

## 7. GripSafe ST IIB Plug Removal

---

- 7.1. Depressurize system using the pressure bleed-off valve on the hydrotest pump equipment.
- 7.2. Remove the hydro pump's hose from the NPT Fill Port to bleed water out of the system.
- 7.3. Use in house procedures to remove the gasket and IIB blind flange from the system.



**CAUTION:** SLOWLY open **Vent Port(10)** to relieve any pressure build up at the back of the plug.

- 7.4. Loosen the **Compression Hex Nut(11)**.

- Continue loosening the **Compression Hex Nut(11)** until the wedges are fully relaxed (Retracted) and the seal has been freed from the pipe.



**NOTE:** Do not remove the **Compression Hex Nuts(19)** from the bolt. If this happens, immediately reinstall the components.

- 7.5. Remove the GripSafe ST IIB plug from the pipe.

- Clean and store for later use or return to USA Industries.
- **Wedge Grippers(15)** texture may become plugged with pipe scale and rust through several uses of the plug. Inspection of this surface after each use is necessary to keep the gripping strength at peak performance. To clean, simply use mild dishwashing soap and a stiff stainless steel bristled brush such as a welding brush. If plugging is persistent, use of a household rust remover along with a stiff stainless steel bristled brush should be sufficient. Rinse plug clean of any residual chemicals with tap water and dry thoroughly.
- Inspect **Wedge Grippers'(15)** freedom of motion. Each **Wedge Gripper(15)** should slide freely up and down in its slot with a full range of motion and without resistance.
- Store out of direct sunlight in an area not exposed to above 150° F, UV light and excessive heat will cause **Seal(6)** degradation over time.



GripSafe® ST is a registered trademark of USA Industries.

