

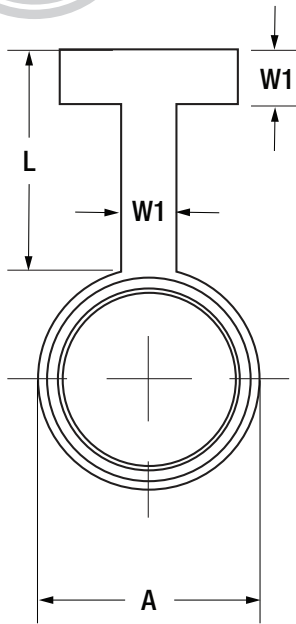

ASME B16.48 ANSI 150# MALE RING TYPE JOINT (RTJ) SPECIFICATIONS

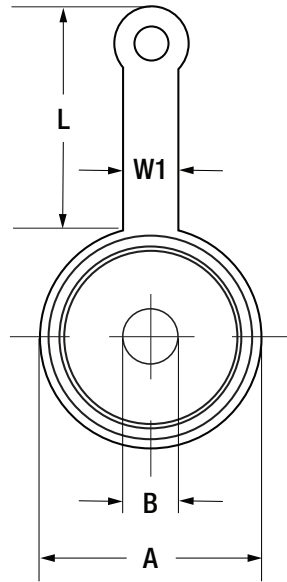

**TYPE 1
PADDLE BLIND**



**TYPE 2
PADDLE SPACER BLIND**

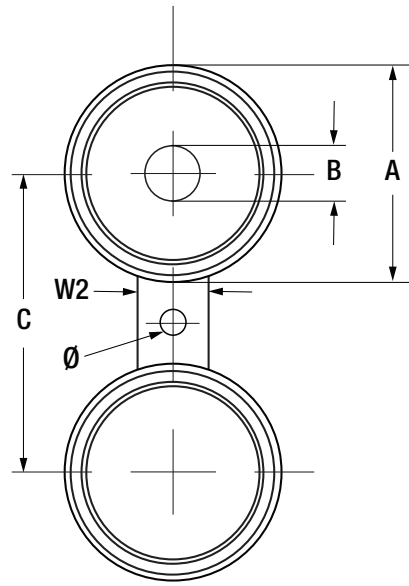

**TYPE 3
SPECTACLE/FIGURE 8 BLIND**

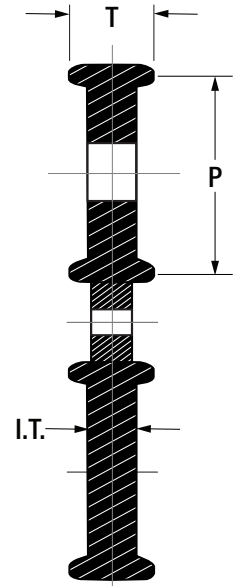

Dimensions (in.)

Approx. Weight (lbs)

SIZE	A	B	C	T	I.T.	P	L	W1	W2	Ø	RING	1	2	3
1	2.19	1.32	3.12	.75	.25	1.875	4.00	1.00	2.00	.625	R-15	2	2	2
1.25	2.56	1.66	3.50	.75	.25	2.25	4.00	1.00	2.00	.625	R-17	2	2	2
1.50	2.87	1.90	3.88	.75	.25	2.562	4.00	1.00	2.25	.625	R-19	2	2	3
2	3.56	2.38	4.75	.75	.25	3.25	4.00	1.00	2.25	.75	R-22	2	2	3
2.50	4.31	2.88	5.50	.88	.38	4.00	4.00	1.00	2.25	.75	R-25	3	2	4
3	4.81	3.50	6.00	.88	.38	4.50	4.00	1.00	2.25	.75	R-29	3	2	5
3.50	5.50	4.00	7.00	.88	.38	5.188	4.00	1.00	2.50	.75	R-33	4	3	6
4	6.19	4.50	7.50	.88	.38	5.875	4.00	1.00	2.50	.75	R-36	5	3	8
5	7.06	5.56	8.50	1.00	.50	6.75	5.00	1.00	3.00	.875	R-40	7	4	8
6	7.94	6.62	9.50	1.00	.50	7.625	5.00	1.00	3.25	.875	R-43	9	4	12
8	10.06	8.62	11.75	1.12	.62	9.75	5.00	1.00	3.75	.875	R-48	15	7	20
10	12.31	10.75	14.25	1.25	.75	12.00	5.00	1.00	4.00	1.00	R-52	24	9	30
12	15.31	12.75	17.00	1.38	.88	15.00	6.00	1.50	4.75	1.00	R-56	39	15	52
14	15.94	14.00	18.75	1.38	.88	16.625	6.00	1.50	5.00	1.125	R-59	44	15	52
16	19.19	16.00	21.25	1.50	1.00	17.875	6.00	1.50	5.00	1.125	R-64	62	19	79
18	20.69	18.00	22.75	1.62	1.12	20.375	6.00	1.50	5.00	1.25	R-68	85	26	110
20	22.31	20.00	25.00	1.62	1.12	22.00	7.00	1.50	5.00	1.25	R-72	105	30	134
24	26.81	24.00	29.50	1.88	1.38	26.50	7.00	1.50	6.00	1.38	R-76	170	46	216

Groove Dimensions are per ASME B16.5. Gasket Surface Finish & Tolerances per ANSI B16.20

Stocked Materials: 516-Gr70 Carbon Steel and 304 | 316 Stainless Steels (can be manufactured with any material you require)

CUSTOM SIZES AND RATINGS AVAILABLE UPON REQUEST



ASME B16.48 ANSI 150# FEMALE RING TYPE JOINT (RTJ) SPECIFICATIONS

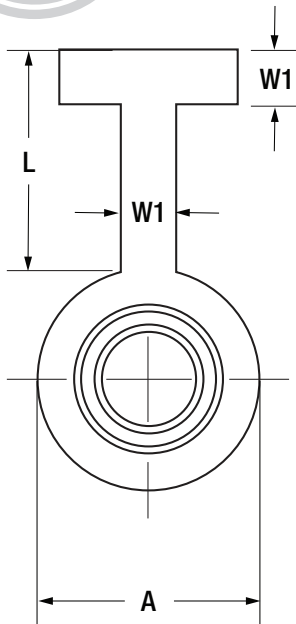

**TYPE 1
PADDLE BLIND**

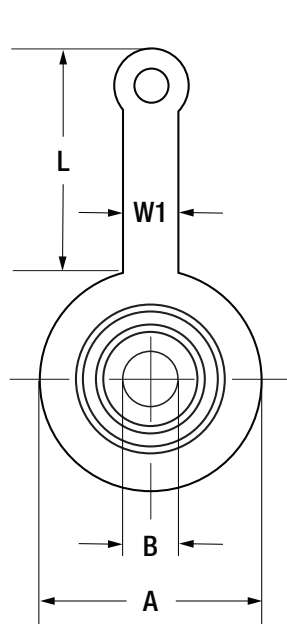

**TYPE 2
PADDLE SPACER BLIND**

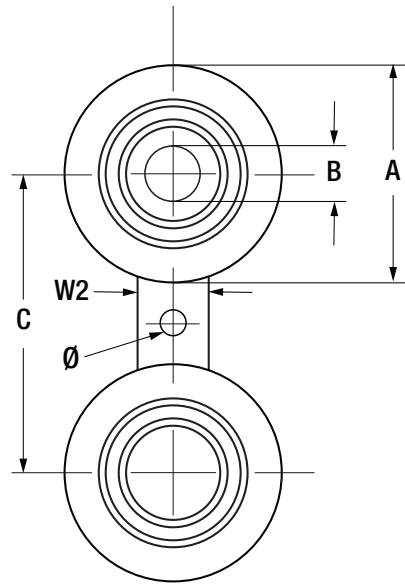

**TYPE 3
SPECTACLE/FIGURE 8 BLIND**

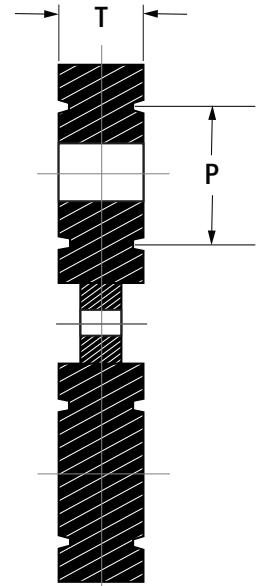

Dimensions (in.)

Approx. Weight (lbs)

SIZE	A	B	C	T	P	L	W1	W2	Ø	RING	1	2	3
1	2.50	1.32	3.12	.75	1.875	4.00	1.00	2.00	.625	R-15	2	1	2
1.25	2.88	1.66	3.50	.75	2.25	4.00	1.00	2.00	.625	R-17	3	2	3
1.50	3.25	1.90	3.88	.75	2.562	4.00	1.00	2.25	.625	R-19	4	3	5
2	4.00	2.38	4.75	.75	3.25	4.00	1.00	2.25	.75	R-22	5	4	7
2.50	4.75	2.88	5.50	.88	4.00	4.00	1.00	2.25	.75	R-25	6	4	9
3	5.25	3.50	6.00	.88	4.50	4.00	1.00	2.25	.75	R-29	7	4	10
3.50	6.06	4.00	7.00	.88	5.188	4.00	1.00	2.50	.75	R-33	8	5	13
4	6.75	4.50	7.50	.88	5.875	4.00	1.00	2.50	.75	R-36	9	6	15
5	7.62	5.56	8.50	1.00	6.75	5.00	1.00	2.75	.875	R-40	14	7	19
6	8.62	6.62	9.50	1.00	7.625	5.00	1.00	3.25	.875	R-43	17	8	23
8	10.75	8.62	11.75	1.12	9.75	5.00	1.00	3.75	.875	R-48	29	11	39
10	13.00	10.75	14.25	1.25	12.00	5.00	1.00	4.00	1.00	R-52	47	17	60
12	16.00	12.75	17.00	1.38	15.00	6.00	1.50	4.75	1.00	R-56	77	30	104
14	16.75	14.00	18.75	1.38	15.625	6.00	1.50	5.00	1.125	R-59	88	30	114
16	19.00	16.00	21.25	1.50	17.875	6.00	1.50	5.00	1.125	R-64	123	38	158
18	21.50	18.00	22.75	1.62	20.375	6.00	1.50	5.00	1.25	R-68	170	52	220
20	23.50	20.00	25.00	1.62	22.00	7.00	1.50	5.00	1.25	R-72	210	60	268
24	28.00	24.00	29.50	1.88	26.50	7.00	1.50	6.00	1.375	R-76	340	92	431

Groove Dimensions are per ASME B16.5. Gasket Surface Finish & Tolerances per ANSI B16.20

Stocked Materials: 516-Gr70 Carbon Steel and 304 | 316 Stainless Steels (can be manufactured with any material you require)

CUSTOM SIZES AND RATINGS AVAILABLE UPON REQUEST



ASME B16.48 ANSI 300# MALE RING TYPE JOINT (RTJ) SPECIFICATIONS

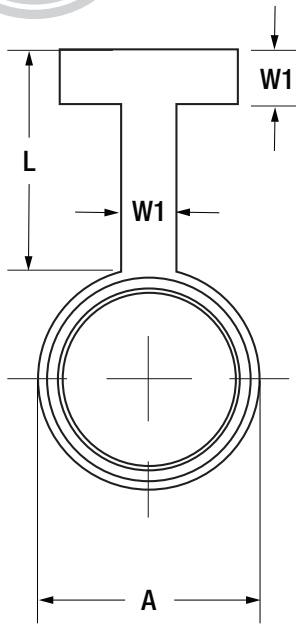

**TYPE 1
PADDLE BLIND**

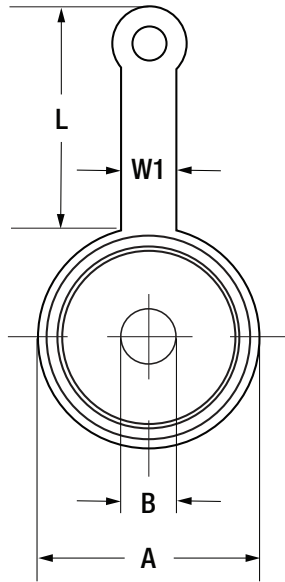

**TYPE 2
PADDLE SPACER BLIND**

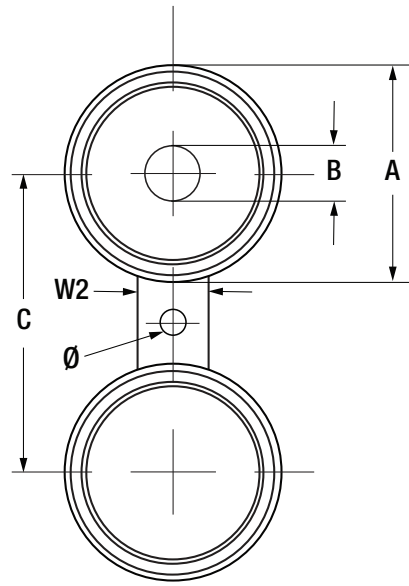

**TYPE 3
SPECTACLE/FIGURE 8 BLIND**

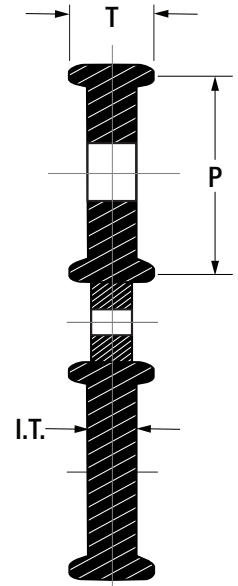

Dimensions (in.)

Approx. Weight (lbs)

SIZE	A	B	C	T	I.T.	P	L	W1	W2	Ø	RING	1	2	3
.50	1.59	.84	2.62	.63	.25	1.344	4.00	1.00	1.50	.625	R-11	1	1	1
.75	2.00	1.05	3.25	.88	.38	1.688	4.00	1.00	1.75	.75	R-13	2	1	2
1	2.31	1.32	3.50	.88	.38	2.00	4.00	1.00	2.00	.75	R-16	2	2	2
1.25	2.69	1.66	3.88	.88	.38	2.375	4.00	1.00	2.00	.75	R-18	2	2	2
1.50	3.00	1.90	4.50	.88	.38	2.688	4.00	1.00	2.25	.875	R-20	2	2	3
2	3.69	2.38	5.00	1.13	.50	3.25	4.00	1.00	2.25	.75	R-23	3	2	3
2.50	4.44	2.88	5.88	1.25	.62	4.00	4.00	1.00	2.25	.875	R-26	3	2	4
3	5.31	3.50	6.62	1.25	.62	4.875	4.00	1.00	2.25	.875	R-31	4	3	5
3.50	5.63	4.00	7.25	1.38	.75	5.188	4.00	1.00	2.50	.875	R-34	5	4	7
4	6.31	4.50	7.88	1.25	.62	5.875	5.00	1.00	2.50	.875	R-37	6	4	9
5	7.56	5.56	9.25	1.38	.75	7.125	5.00	1.00	3.00	.875	R-41	11	7	15
6	8.75	6.62	10.62	1.51	.88	8.312	5.00	1.00	3.25	.875	R-45	15	9	20
8	11.06	8.62	13.00	1.63	1.00	10.625	5.00	1.00	3.75	1.00	R-49	28	15	39
10	13.19	10.75	15.25	1.75	1.12	12.75	5.00	1.00	4.00	1.125	R-53	42	20	62
12	15.44	12.75	17.75	2.01	1.38	15.00	6.00	1.50	4.75	1.25	R-57	62	23	90
14	16.94	14.00	20.25	2.13	1.50	16.50	6.00	1.50	5.00	1.25	R-61	76	31	105
16	18.94	16.00	22.50	2.25	1.62	18.50	6.00	1.50	5.00	1.375	R-65	102	38	138
18	21.44	18.00	24.75	2.38	1.75	21.00	7.00	1.50	5.00	1.375	R-69	140	52	192
20	23.50	20.00	27.00	2.69	2.00	23.00	7.00	1.50	5.00	1.375	R-73	193	70	264
24	27.88	24.00	32.00	3.06	2.25	27.25	7.00	1.50	6.00	1.625	R-77	317	108	425

Groove Dimensions are per ASME B16.5. Gasket Surface Finish & Tolerances per ANSI B16.20

Stocked Materials: 516-Gr70 Carbon Steel and 304 | 316 Stainless Steels (can be manufactured with any material you require)

CUSTOM SIZES AND RATINGS AVAILABLE UPON REQUEST



ASME B16.48 ANSI 300# FEMALE RING TYPE JOINT (RTJ) SPECIFICATIONS

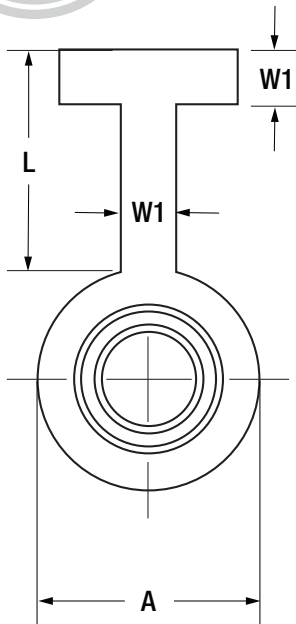

**TYPE 1
PADDLE BLIND**

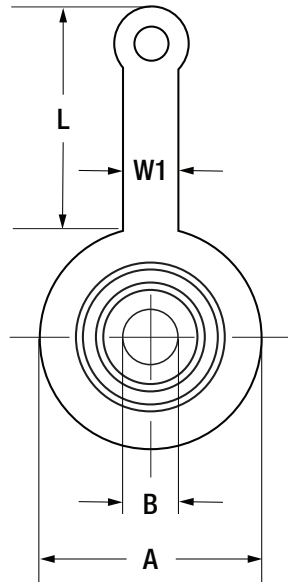

**TYPE 2
PADDLE SPACER BLIND**

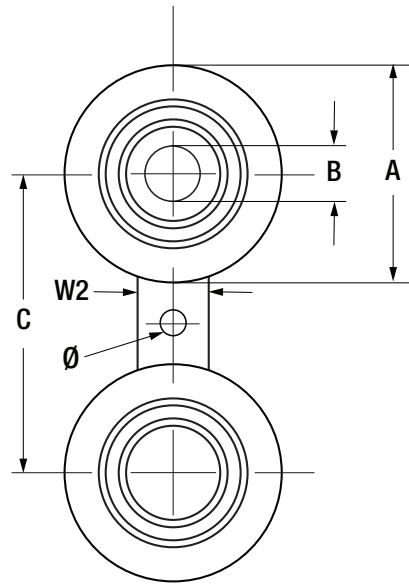

**TYPE 3
SPECTACLE/FIGURE 8 BLIND**

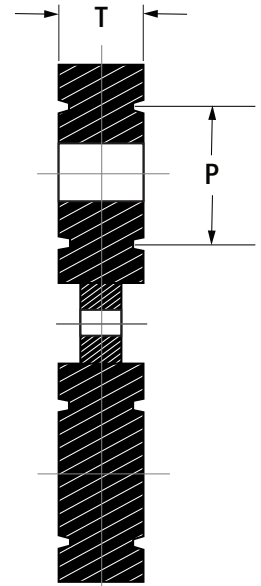

Dimensions (in.)

Approx. Weight (lbs)

SIZE	A	B	C	T	P	L	W1	W2	Ø	RING	1	2	3
.50	2.00	.84	2.62	.62	1.344	4.00	1.00	1.50	.625	R-11	1	1	1
.75	2.50	1.05	3.25	.75	1.688	4.00	1.00	1.75	.75	R-13	2	1	2
1	2.75	1.32	3.50	.75	2.00	4.00	1.00	2.00	.75	R-16	3	2	4
1.25	3.12	1.66	3.88	.88	2.375	4.00	1.00	2.00	.75	R-18	3	3	5
1.50	3.56	1.90	4.50	.88	2.688	4.00	1.00	2.25	.875	R-20	4	3	6
2	4.25	2.38	5.00	1.00	3.25	4.00	1.00	2.25	.75	R-23	5	4	8
2.50	5.00	2.88	5.88	1.12	4.00	4.00	1.00	2.25	.875	R-26	7	5	11
3	5.75	3.50	6.62	1.125	4.875	4.00	1.00	2.25	.875	R-31	9	6	14
3.50	6.25	4.00	7.25	1.12	5.188	4.00	1.00	2.50	.875	R-34	12	8	17
4	6.88	4.50	7.88	1.25	5.875	5.00	1.00	2.50	.875	R-37	14	9	21
5	8.25	5.56	9.25	1.38	7.125	5.00	1.00	2.75	.875	R-41	22	13	32
6	9.50	6.62	10.62	1.38	8.312	5.00	1.00	3.25	.875	R-45	29	16	43
8	11.88	8.62	13.00	1.62	10.625	5.00	1.00	3.75	1.00	R-49	53	27	77
10	14.00	10.75	15.25	1.75	12.75	5.00	1.00	4.00	1.125	R-53	82	35	113
12	16.25	12.75	17.75	2.00	15.00	6.00	1.50	4.75	1.25	R-57	120	48	165
14	18.00	14.00	20.25	2.12	16.50	6.00	1.50	5.00	1.25	R-61	151	61	210
16	20.00	16.00	22.50	2.25	18.50	6.00	1.50	5.00	1.375	R-65	203	75	276
18	22.62	18.00	24.75	2.38	21.00	7.00	1.50	5.00	1.375	R-69	280	104	383
20	25.00	20.00	27.00	2.75	23.00	7.00	1.50	5.00	1.375	R-73	385	140	527
24	29.50	24.00	32.00	3.12	27.25	7.00	1.50	6.00	1.625	R-77	633	216	849

Groove Dimensions are per ASME B16.5. Gasket Surface Finish & Tolerances per ANSI B16.20

Stocked Materials: 516-Gr70 Carbon Steel and 304 | 316 Stainless Steels (can be manufactured with any material you require)

CUSTOM SIZES AND RATINGS AVAILABLE UPON REQUEST



ASME B16.48 ANSI 600# MALE RING TYPE JOINT (RTJ) SPECIFICATIONS

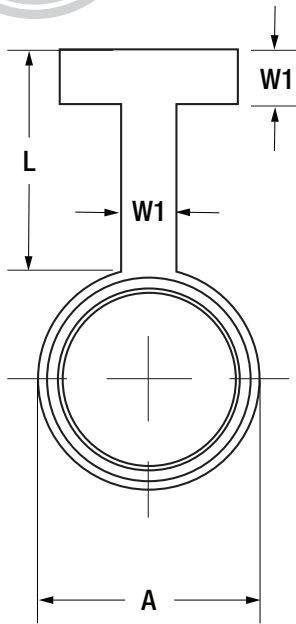

**TYPE 1
PADDLE BLIND**

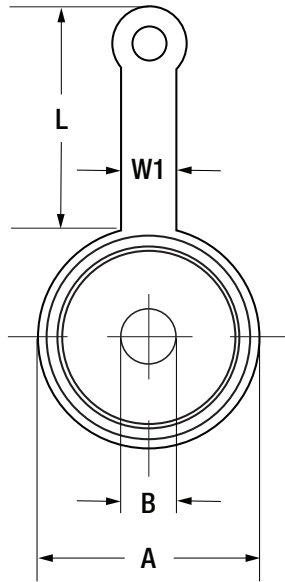

**TYPE 2
PADDLE SPACER BLIND**

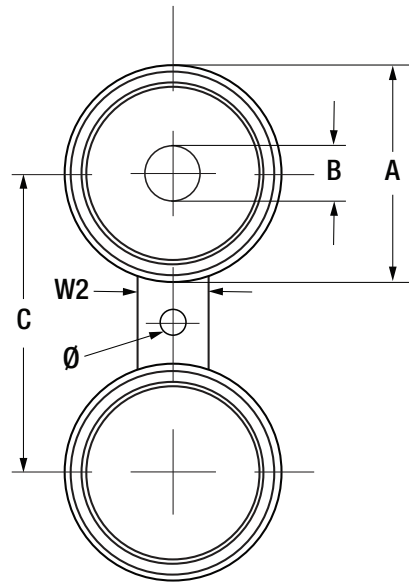

**TYPE 3
SPECTACLE/FIGURE 8 BLIND**

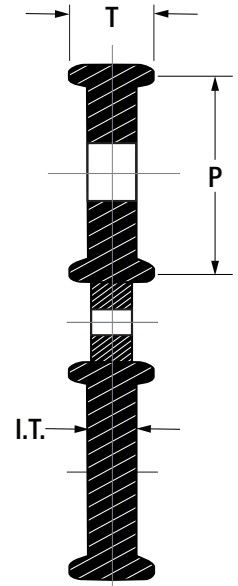

Dimensions (in.)

Approx. Weight (lbs)

SIZE	A	B	C	T	I.T.	P	L	W1	W2	Ø	RING	1	2	3
.50	1.59	.84	2.62	.63	.25	1.344	4.00	1.00	1.50	.625	R-11	1	1	1
.75	2.00	1.05	3.25	.88	.38	1.688	4.00	1.00	1.75	.75	R-13	1	1	1
1	2.31	1.32	3.50	.88	.38	2.00	4.00	1.00	2.00	.75	R-16	2	2	2
1.25	2.69	1.66	3.88	.88	.38	2.375	4.00	1.00	2.00	.75	R-18	3	2	3
1.50	3.00	1.90	4.50	.88	.38	2.688	4.00	1.00	2.25	.875	R-20	3	2	3
2	3.69	2.38	5.00	1.13	.50	3.25	4.00	1.00	2.25	.75	R-23	3	3	4
2.50	4.44	2.88	5.88	1.25	.62	4.00	4.00	1.00	2.25	.875	R-26	4	3	6
3	5.31	3.50	6.62	1.25	.62	4.875	4.00	1.00	2.25	.875	R-31	5	4	7
3.50	5.63	4.00	7.25	1.38	.75	5.188	4.00	1.00	2.50	1.00	R-34	7	6	10
4	6.31	4.50	8.50	1.38	.75	5.875	5.00	1.00	2.50	1.00	R-37	9	7	14
5	7.56	5.56	10.50	1.51	.88	7.125	5.00	1.00	3.00	1.125	R-41	17	11	25
6	8.75	6.62	11.50	1.75	1.12	8.312	5.00	1.00	3.25	1.125	R-45	23	15	35
8	11.06	8.62	13.75	2.01	1.38	10.625	5.00	1.00	3.75	1.25	R-49	41	23	62
10	13.19	10.75	17.00	2.25	1.62	12.75	5.00	1.00	4.00	1.375	R-54	71	40	112
12	15.44	12.75	19.25	2.51	1.88	15.00	6.00	1.50	4.75	1.375	R-57	106	51	162
14	16.94	14.00	20.75	2.63	2.00	16.50	6.00	1.50	5.00	1.50	R-61	112	58	134
16	18.94	16.00	23.75	2.88	2.25	18.50	6.00	1.50	5.00	1.625	R-65	130	65	176
18	21.44	18.00	25.75	3.13	2.50	21.00	7.00	1.50	5.00	1.75	R-69	184	69	251
20	23.50	20.00	28.50	3.44	2.75	23.00	7.00	1.50	5.00	1.75	R-73	250	91	340
24	27.88	24.00	33.00	4.06	3.25	27.25	7.00	1.50	6.00	2.00	R-77	407	139	547

Groove Dimensions are per ASME B16.5. Gasket Surface Finish & Tolerances per ANSI B16.20

Stocked Materials: 516-Gr70 Carbon Steel and 304 | 316 Stainless Steels (can be manufactured with any material you require)

CUSTOM SIZES AND RATINGS AVAILABLE UPON REQUEST



ASME B16.48 ANSI 600# FEMALE RING TYPE JOINT (RTJ) SPECIFICATIONS

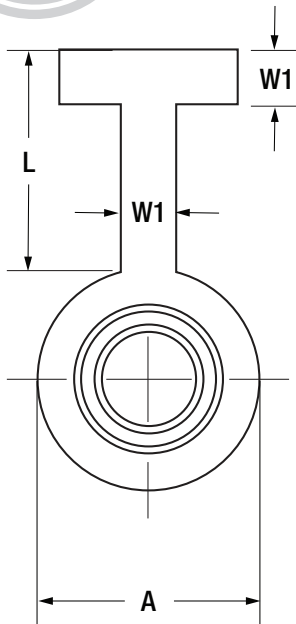

**TYPE 1
PADDLE BLIND**

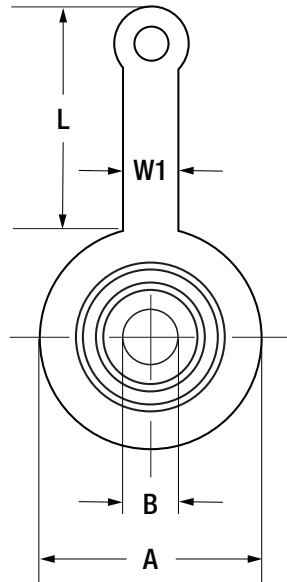

**TYPE 2
PADDLE SPACER BLIND**

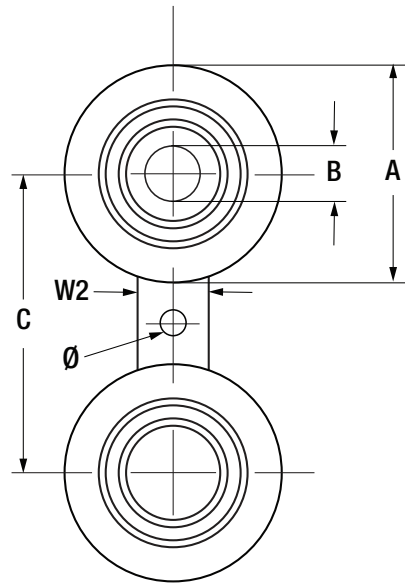

**TYPE 3
SPECTACLE/FIGURE 8 BLIND**

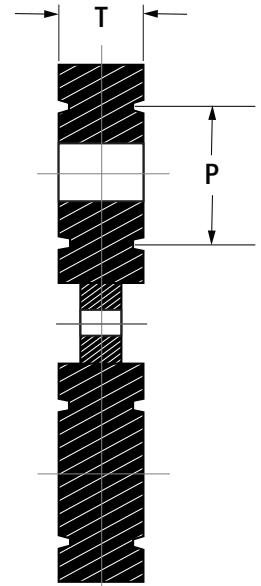

Dimensions (in.)

Approx. Weight (lbs)

SIZE	A	B	C	T	P	L	W1	W2	Ø	RING	1	2	3
.50	2.00	.84	2.62	.75	1.344	4.00	1.00	1.50	.625	R-11	1	1	1
.75	2.50	1.05	3.25	.88	1.688	4.00	1.00	1.75	.75	R-13	1	1	1
1	2.75	1.32	3.50	.88	2.00	4.00	1.00	2.00	.75	R-16	2	1	2
1.25	3.12	1.66	3.88	.88	2.375	4.00	1.00	2.00	.75	R-18	3	3	4
1.50	3.56	1.90	4.50	.88	2.688	4.00	1.00	2.25	.875	R-20	4	3	6
2	4.25	2.38	5.00	1.12	3.25	4.00	1.00	2.25	.75	R-23	6	4	9
2.50	5.00	2.88	5.88	1.25	4.00	4.00	1.00	2.25	.875	R-26	8	6	13
3	5.75	3.50	6.62	1.25	4.875	4.00	1.00	2.25	.875	R-31	11	7	16
3.50	6.25	4.00	7.25	1.38	5.188	4.00	1.00	2.50	1.00	R-34	13	9	20
4	6.88	4.50	8.50	1.38	5.875	5.00	1.00	2.50	1.00	R-37	16	10	24
5	8.25	5.56	10.50	1.50	7.125	5.00	1.00	2.75	1.125	R-41	24	15	39
6	9.50	6.62	11.50	1.75	8.312	5.00	1.00	3.25	1.125	R-45	36	20	53
8	11.88	8.62	13.75	2.00	10.625	6.00	1.00	3.75	1.25	R-49	65	32	95
10	14.00	10.75	17.00	2.25	12.75	6.00	1.00	4.00	1.375	R-53	98	42	137
12	16.25	12.75	19.25	2.50	15.00	6.00	1.50	4.75	1.375	R-57	146	58	202
14	18.00	14.00	20.75	2.62	16.50	6.00	1.50	5.00	1.50	R-61	165	67	229
16	20.00	16.00	23.75	2.88	18.50	7.00	1.50	5.00	1.625	R-65	225	83	386
18	22.62	18.00	25.75	3.12	21.00	7.00	1.50	5.00	1.75	R-69	367	137	502
20	25.00	20.00	28.50	3.50	23.00	7.00	1.50	5.00	1.75	R-73	499	182	679
24	29.50	24.00	33.00	4.12	27.25	8.00	1.50	6.00	2.00	R-77	814	278	1094

Groove Dimensions are per ASME B16.5. Gasket Surface Finish & Tolerances per ANSI B16.20

Stocked Materials: 516-Gr70 Carbon Steel and 304 | 316 Stainless Steels (can be manufactured with any material you require)

CUSTOM SIZES AND RATINGS AVAILABLE UPON REQUEST



ASME B16.48 ANSI 900# MALE RING TYPE JOINT (RTJ) SPECIFICATIONS

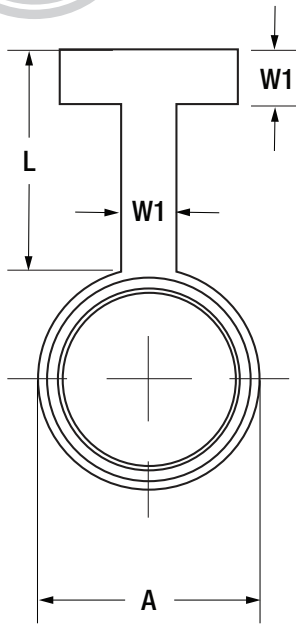

**TYPE 1
PADDLE BLIND**

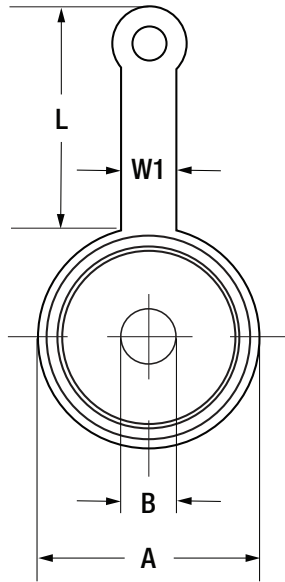

**TYPE 2
PADDLE SPACER BLIND**

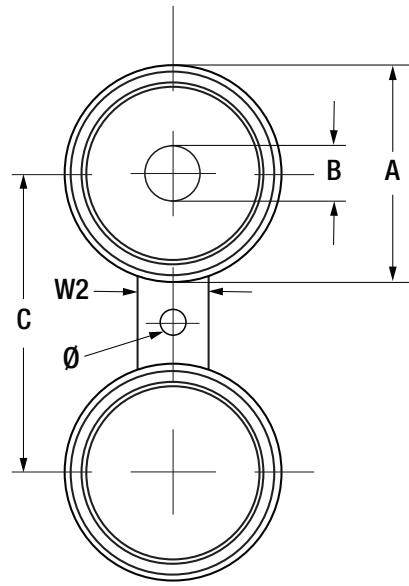

**TYPE 3
SPECTACLE/FIGURE 8 BLIND**

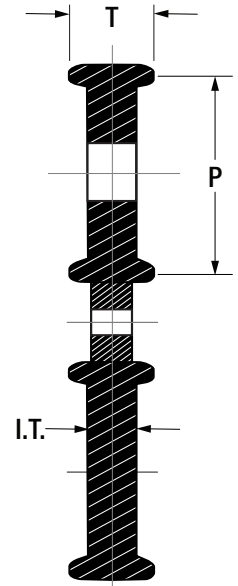

Dimensions (in.)

Approx. Weight (lbs)

SIZE	A	B	C	T	I.T.	P	L	W1	W2	Ø	RING	1	2	3
.50	1.87	.84	3.25	.88	.38	1.562	5.00	1.00	1.50	.875	R-12	1	1	1
.75	2.06	1.05	3.50	.88	.38	1.75	5.00	1.00	1.75	.875	R-14	1	1	1
1	2.31	1.32	4.00	.88	.38	2.00	5.00	1.00	2.00	1.00	R-16	2	2	2
1.25	2.69	1.66	4.38	1.00	.50	2.375	5.00	1.00	2.12	1.00	R-18	3	2	3
1.50	3.00	1.90	4.88	1.00	.50	2.688	5.00	1.00	2.12	1.125	R-20	3	3	3
2	4.19	2.38	6.50	1.25	.62	3.75	5.00	1.00	2.00	1.00	R-24	3	3	4
2.50	4.69	2.88	7.50	1.38	.75	4.25	6.00	1.00	2.12	1.125	R-27	4	3	6
3	5.31	3.50	7.50	1.38	.75	4.875	6.00	1.00	2.62	1.00	R-31	7	6	12
4	6.31	4.50	9.25	1.63	1.00	5.875	6.00	1.00	2.88	1.25	R-37	14	10	19
5	7.56	5.56	11.00	1.75	1.12	7.125	6.00	1.00	2.88	1.375	R-41	23	16	33
6	8.75	6.62	12.50	1.88	1.25	8.312	6.00	1.00	2.88	1.25	R-45	32	22	47
8	11.06	8.62	15.50	2.25	1.62	10.625	7.00	1.00	3.12	1.50	R-49	59	38	95
10	13.19	10.75	18.50	2.51	1.88	12.75	7.00	1.00	4.75	1.50	R-53	102	66	170
12	15.44	12.75	21.00	2.88	2.25	15.00	7.00	1.50	4.75	1.50	R-57	157	92	250
14	17.13	14.00	22.00	3.19	2.38	16.50	7.00	1.50	4.75	1.625	R-62	165	100	270
16	19.13	16.00	24.25	3.56	2.75	18.50	7.00	1.50	5.00	1.75	R-66	174	120	290
18	21.75	18.00	27.00	3.94	3.00	21.00	8.00	1.50	5.25	2.00	R-70	253	135	356
20	23.75	20.00	29.50	4.32	3.38	23.00	8.00	1.50	5.00	2.125	R-74	323	150	449
24	28.25	24.00	35.50	5.13	3.88	27.25	8.00	1.50	6.00	2.625	R-78	547	200	756

Groove Dimensions are per ASME B16.5. Gasket Surface Finish & Tolerances per ANSI B16.20

Stocked Materials: 516-Gr70 Carbon Steel and 304 | 316 Stainless Steels (can be manufactured with any material you require)

CUSTOM SIZES AND RATINGS AVAILABLE UPON REQUEST



ASME B16.48 ANSI 900# FEMALE RING TYPE JOINT (RTJ) SPECIFICATIONS

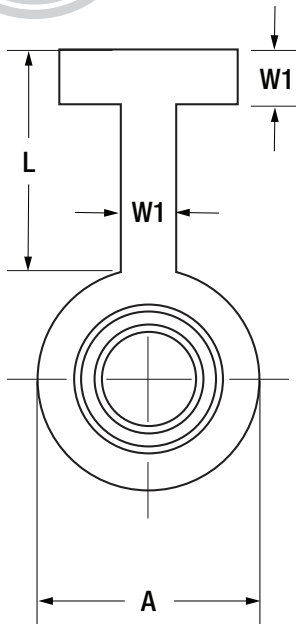

**TYPE 1
PADDLE BLIND**

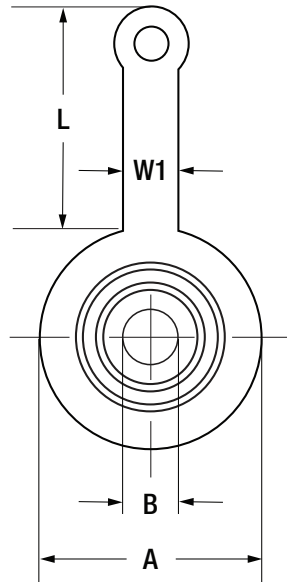

**TYPE 2
PADDLE SPACER BLIND**

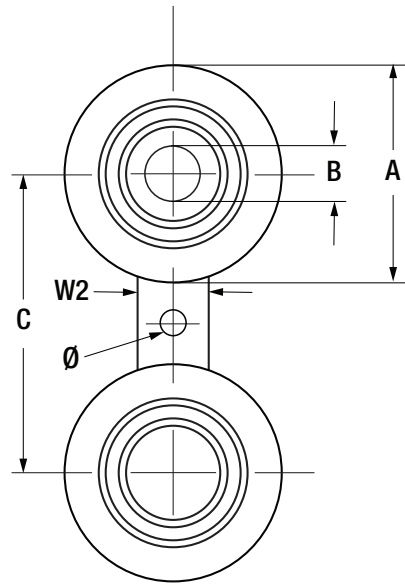

**TYPE 3
SPECTACLE/FIGURE 8 BLIND**

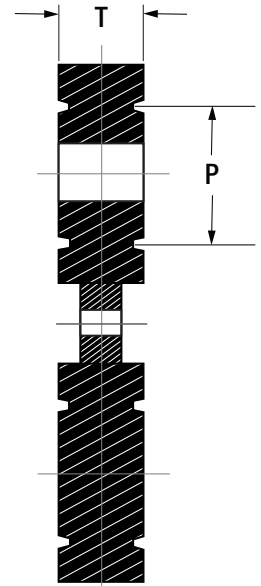

Dimensions (in.)

Approx. Weight (lbs)

SIZE	A	B	C	T	P	L	W1	W2	Ø	RING	1	2	3
.50	2.38	.84	3.25	.88	1.562	5.00	1.00	1.50	.875	R-12	1	1	1
.75	2.62	1.05	3.50	.88	1.75	5.00	1.00	1.75	.875	R-14	2	2	2
1	2.81	1.32	4.00	.88	2.00	5.00	1.00	2.00	1.00	R-16	3	3	4
1.25	3.19	1.66	4.38	1.00	2.375	5.00	1.00	2.00	1.00	R-18	4	3	5
1.50	3.62	1.90	4.88	1.00	2.688	5.00	1.00	2.50	1.125	R-20	5	4	6
2	4.88	2.38	6.50	1.25	3.75	5.00	1.00	2.00	1.00	R-24	8	7	13
2.50	5.38	2.88	7.50	1.38	4.25	6.00	1.00	2.62	1.125	R-27	11	8	18
3	6.12	3.50	7.50	1.38	4.875	6.00	1.00	2.62	1.00	R-31	13	9	21
4	7.12	4.50	9.25	1.62	5.875	6.00	1.00	2.88	1.25	R-37	20	13	30
5	8.50	5.56	11.00	1.75	7.125	6.00	1.00	2.88	1.375	R-41	32	25	45
6	9.50	6.62	12.50	1.88	8.312	6.00	1.00	2.88	1.25	R-45	41	22	60
8	12.12	8.62	15.50	2.25	10.625	7.00	1.00	3.12	1.50	R-49	77	40	112
10	14.25	10.75	18.50	2.50	12.75	7.00	1.00	4.75	1.50	R-53	119	53	169
12	16.50	12.75	21.00	2.88	15.00	7.00	1.50	4.75	1.50	R-57	178	74	249
14	18.38	14.00	22.00	3.25	16.50	7.00	1.50	4.75	1.625	R-62	252	108	346
16	20.62	16.00	24.25	3.62	18.50	7.00	1.50	5.00	1.75	R-66	347	140	484
18	23.38	18.00	27.00	4.00	21.00	8.00	1.50	5.25	2.00	R-70	505	208	712
20	25.50	20.00	29.50	4.38	23.00	8.00	1.50	5.00	2.125	R-74	646	251	898
24	30.38	24.00	35.50	5.25	27.25	8.00	1.50	5.50	2.625	R-78	1094	413	1512

Groove Dimensions are per ASME B16.5. Gasket Surface Finish & Tolerances per ANSI B16.20

Stocked Materials: 516-Gr70 Carbon Steel and 304 | 316 Stainless Steels (can be manufactured with any material you require)

CUSTOM SIZES AND RATINGS AVAILABLE UPON REQUEST



ASME B16.48 ANSI 1500# MALE RING TYPE JOINT (RTJ) SPECIFICATIONS

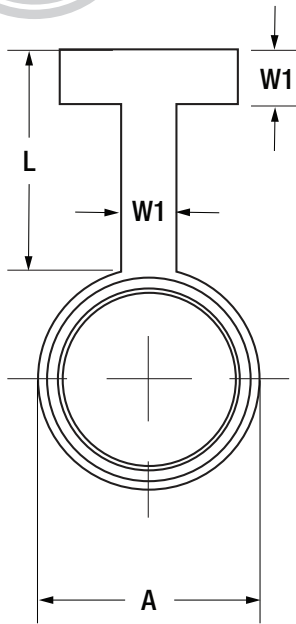

**TYPE 1
PADDLE BLIND**

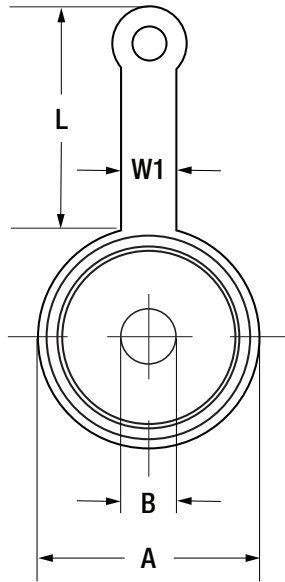

**TYPE 2
PADDLE SPACER BLIND**

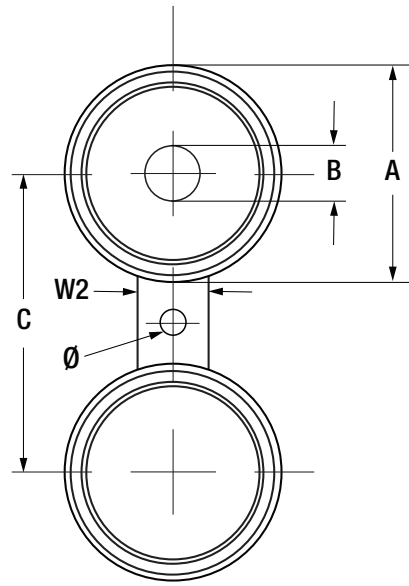

**TYPE 3
SPECTACLE/FIGURE 8 BLIND**

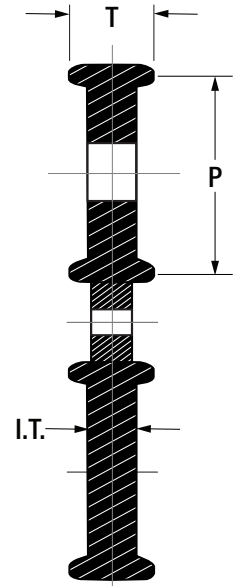

Dimensions (in.)

Approx. Weight (lbs)

SIZE	A	B	C	T	I.T.	P	L	W1	W2	Ø	RING	1	2	3
.50	1.87	.84	3.25	.88	.38	1.562	5.00	1.00	1.50	.875	R-11	1	1	1
.75	2.06	1.05	3.50	.88	.38	1.75	5.00	1.00	1.75	.875	R-13	1	1	2
1	2.31	1.32	4.00	1.00	.50	2.00	5.00	1.00	2.12	1.00	R-16	2	2	3
1.25	2.69	1.66	4.38	1.00	.50	2.375	5.00	1.00	2.12	1.00	R-18	2	2	3
1.50	3.00	1.90	4.88	1.12	.62	2.688	5.00	1.00	2.25	1.125	R-20	3	3	4
2	4.19	2.38	6.50	1.38	.75	3.75	5.00	1.00	2.12	1.00	R-23	5	4	8
2.50	4.69	2.88	7.50	1.51	.88	4.25	6.00	1.00	2.25	1.125	R-26	7	5	11
3	5.81	3.50	8.00	1.75	1.12	5.375	6.00	1.00	2.88	1.25	R-31	9	7	16
4	6.81	4.50	9.50	1.88	1.25	6.375	6.00	1.00	3.00	1.375	R-37	17	14	27
5	8.06	5.56	11.50	2.13	1.50	7.625	6.00	1.00	3.00	1.625	R-41	24	18	44
6	8.81	6.62	12.50	2.30	1.62	8.312	6.00	1.00	3.12	1.50	R-45	36	22	61
8	11.25	8.62	15.50	2.81	2.00	10.62	7.00	1.00	3.38	1.75	R-49	68	41	110
10	13.38	10.75	19.00	3.31	2.50	12.75	8.00	1.00	5.25	2.00	R-54	128	75	205
12	15.88	12.75	22.50	3.94	2.88	15.00	8.00	1.50	5.25	2.125	R-57	210	127	340
14	17.50	14.00	25.00	4.43	3.12	16.50	9.00	1.50	5.50	2.375	R-61	220	140	360
16	19.63	16.00	27.75	4.88	3.50	18.50	9.00	1.50	5.75	2.625	R-65	256	155	372
18	22.13	18.00	30.50	5.26	3.88	21.00	10.00	1.50	6.00	2.875	R-69	350	165	508
20	24.25	20.00	32.75	5.75	4.25	23.00	10.00	1.50	6.50	3.125	R-73	456	197	657
24	28.63	24.00	39.00	6.63	5.00	27.25	10.00	1.50	7.00	3.625	R-77	742	305	1054

Groove Dimensions are per ASME B16.5. Gasket Surface Finish & Tolerances per ANSI B16.20

Stocked Materials: 516-Gr70 Carbon Steel and 304 | 316 Stainless Steels (can be manufactured with any material you require)

CUSTOM SIZES AND RATINGS AVAILABLE UPON REQUEST



ASME B16.48 ANSI 1500# FEMALE RING TYPE JOINT (RTJ) SPECIFICATIONS

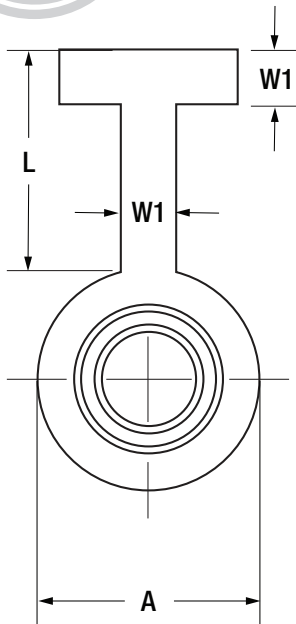

**TYPE 1
PADDLE BLIND**

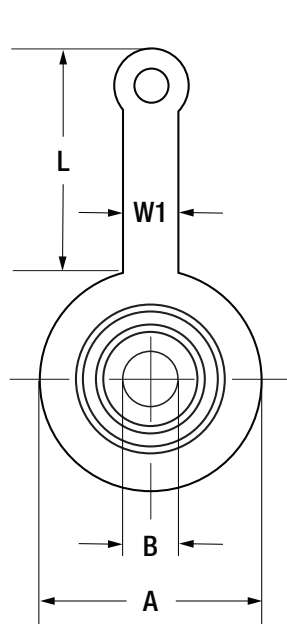

**TYPE 2
PADDLE SPACER BLIND**

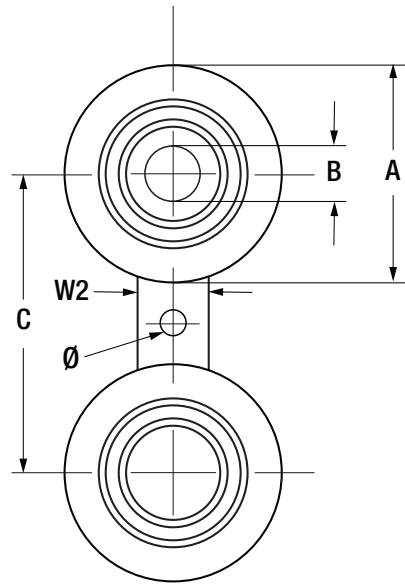

**TYPE 3
SPECTACLE/FIGURE 8 BLIND**

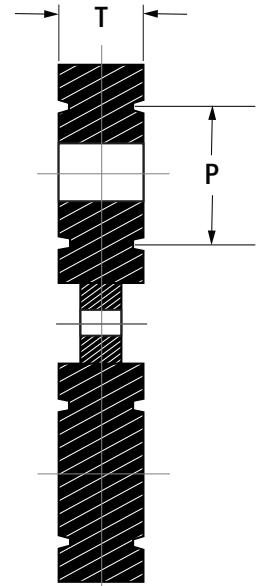

Dimensions (in.)

Approx. Weight (lbs)

SIZE	A	B	C	T	P	L	W1	W2	Ø	RING	1	2	3
.50	2.38	.84	3.25	.88	1.562	5.00	1.00	1.50	.875	R-12	1	1	1
.75	2.62	1.05	3.50	1.00	1.75	5.00	1.00	1.75	.875	R-14	2	2	2
1	2.81	1.32	4.00	1.00	2.00	5.00	1.00	2.00	1.00	R-16	3	3	4
1.25	3.19	1.66	4.38	1.00	2.375	5.00	1.00	2.12	1.00	R-18	4	3	5
1.50	3.62	1.90	4.88	1.12	2.688	5.00	1.00	2.25	1.125	R-20	5	4	6
2	4.88	2.38	6.50	1.38	3.75	5.00	1.00	2.12	1.00	R-24	8	7	13
2.50	5.38	2.88	7.50	1.50	4.25	6.00	1.00	2.25	1.125	R-27	11	8	18
3	6.62	3.50	8.00	1.75	5.375	6.00	1.00	2.88	1.25	R-35	19	14	31
4	7.62	4.50	9.50	1.88	6.375	6.00	1.00	3.00	1.375	R-39	28	19	43
5	9.00	5.56	11.50	2.12	7.625	6.00	1.00	3.00	1.625	R-44	41	25	61
6	9.75	6.62	12.50	2.38	8.312	6.00	1.00	3.12	1.50	R-46	53	30	79
8	12.50	8.62	15.50	2.88	10.625	7.00	1.00	3.38	1.75	R-50	106	57	159
10	14.62	10.75	19.00	3.25	12.75	8.00	1.00	5.25	2.00	R-54	161	76	236
12	17.25	12.75	22.50	4.00	15.00	8.00	1.50	5.25	2.125	R-58	268	124	390
14	19.25	14.00	25.00	4.38	16.50	9.00	1.50	5.50	2.375	R-63	365	174	539
16	21.50	16.00	27.75	4.88	18.50	9.00	1.50	5.75	2.625	R-67	511	230	744
18	24.12	18.00	30.50	5.25	21.00	10.00	1.50	6.00	2.875	R-71	700	312	1015
20	26.50	20.00	32.75	5.62	23.00	10.00	1.50	6.50	3.125	R-75	912	394	1313
24	31.25	24.00	39.00	6.62	27.25	10.00	1.50	7.00	3.625	R-79	1484	611	2108

Groove Dimensions are per ASME B16.5. Gasket Surface Finish & Tolerances per ANSI B16.20

Stocked Materials: 516-Gr70 Carbon Steel and 304 | 316 Stainless Steels (can be manufactured with any material you require)

CUSTOM SIZES AND RATINGS AVAILABLE UPON REQUEST



ASME B16.48 ANSI 2500# MALE RING TYPE JOINT (RTJ) SPECIFICATIONS

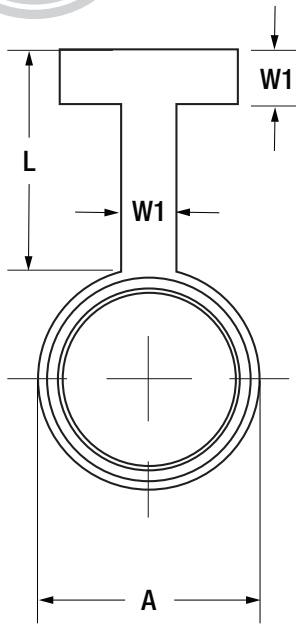

**TYPE 1
PADDLE BLIND**

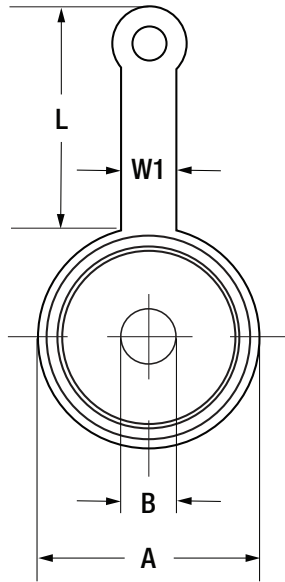

**TYPE 2
PADDLE SPACER BLIND**

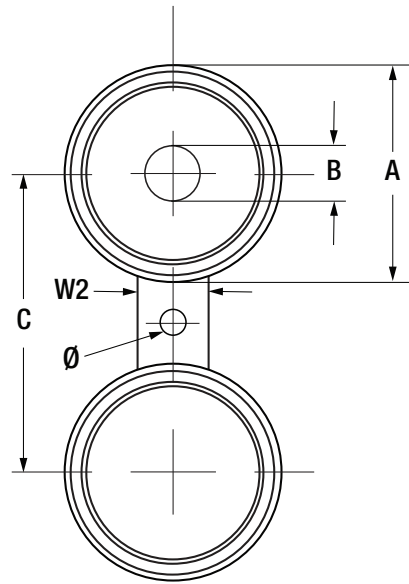

**TYPE 3
SPECTACLE/FIGURE 8 BLIND**

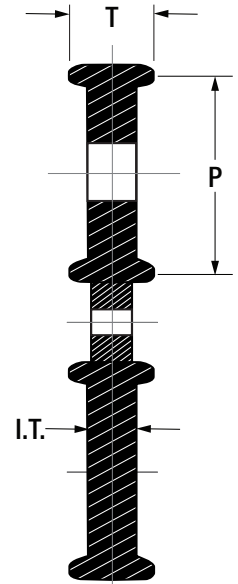

Dimensions (in.)

Approx. Weight (lbs)

SIZE	A	B	C	T	I.T.	P	L	W1	W2	Ø	RING	1	2	3
0.50	2.00	0.84	3.50	1.00	.50	1.688	5.00	1.00	1.62	0.875	R-13	1	1	1
0.75	2.31	1.05	3.75	1.12	.62	2.00	5.00	1.00	1.88	0.875	R-16	2	2	2
1	2.69	1.32	4.25	1.12	.62	2.375	5.00	1.00	2.12	1.00	R-18	3	3	4
1.25	3.28	1.66	5.12	1.38	.75	2.844	5.00	1.00	2.12	1.125	R-21	3	3	4
1.5	3.69	1.90	5.75	1.51	.88	3.25	5.00	1.00	2.38	1.25	R-23	4	4	6
2	4.44	2.38	6.75	1.63	1.00	4.00	5.00	1.00	2.25	1.125	R-26	8	6	12
2.5	4.88	2.88	7.75	1.81	1.12	4.375	6.00	1.00	2.38	1.25	R-28	10	7	17
3	5.50	3.50	9.00	1.94	1.25	5.00	6.00	1.00	3.00	1.375	R-32	15	11	24
4	6.81	4.50	10.75	2.31	1.50	6.188	7.00	1.00	3.25	1.625	R-38	25	16	41
5	8.25	5.56	12.75	2.82	1.88	7.50	7.00	1.00	3.50	1.875	R-42	41	26	66
6	9.75	6.62	14.50	3.19	2.25	9.00	8.00	1.00	3.75	2.125	R-47	57	35	91
8	11.88	8.62	17.25	3.81	2.75	11.00	8.00	1.00	3.75	2.125	R-51	102	63	165
10	14.63	10.75	21.25	4.63	3.25	13.50	9.00	1.50	3.75	2.625	R-55	190	115	306
12	17.25	12.75	24.38	5.38	3.88	16.00	9.00	1.50	6.00	2.875	R-60	312	187	507

Groove Dimensions are per ASME B16.5. Gasket Surface Finish & Tolerances per ANSI B16.20

Stocked Materials: 516-Gr70 Carbon Steel and 304 | 316 Stainless Steels (can be manufactured with any material you require)

CUSTOM SIZES AND RATINGS AVAILABLE UPON REQUEST



ASME B16.48 ANSI 2500# FEMALE RING TYPE JOINT (RTJ) SPECIFICATIONS

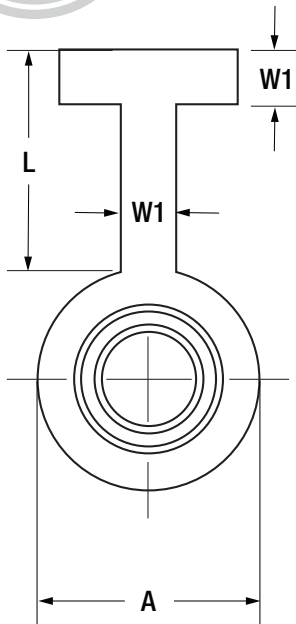

**TYPE 1
PADDLE BLIND**

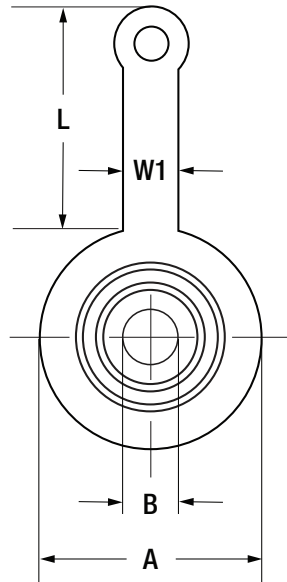

**TYPE 2
PADDLE SPACER BLIND**

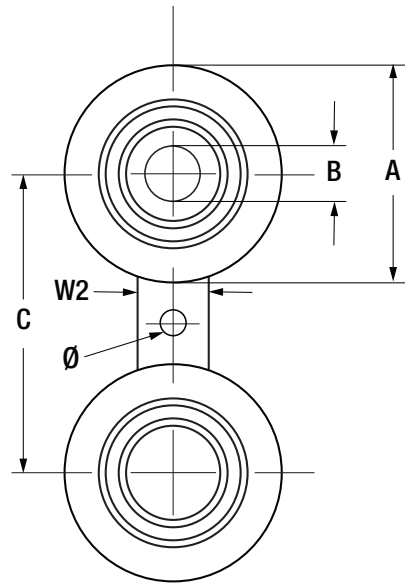

**TYPE 3
SPECTACLE/FIGURE 8 BLIND**

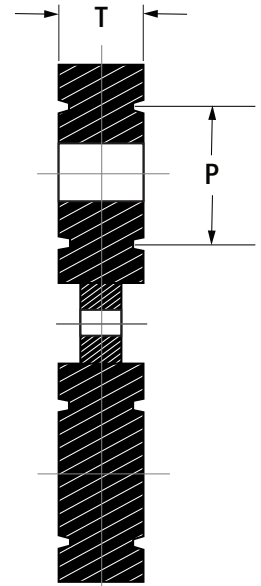

Dimensions (in.)

Approx. Weight (lbs)

SIZE	A	B	C	T	P	L	W1	W2	Ø	RING	1	2	3
0.5	2.56	0.84	3.50	1.00	1.688	5.00	1.00	1.50	0.875	R-13	2	2	4
0.75	2.88	1.05	3.75	1.12	2.00	5.00	1.00	1.75	0.875	R-16	3	3	5
1	3.25	1.32	4.25	1.12	2.375	5.00	1.00	2.12	1.00	R-18	4	4	6
1.25	4.00	1.66	5.12	1.38	2.844	5.00	1.00	2.12	1.125	R-21	7	5	10
1.5	4.50	1.90	5.75	1.50	3.25	5.00	1.00	2.38	1.25	R-23	8	7	14
2	5.25	2.38	6.75	1.62	4.00	5.00	1.00	2.25	1.125	R-26	13	11	20
2.5	5.88	2.88	7.75	1.88	4.375	6.00	1.00	2.38	1.25	R-28	17	13	27
3	6.62	3.50	9.00	2.00	5.00	6.00	1.00	3.00	1.375	R-32	22	17	35
4	8.00	4.50	10.75	2.50	6.188	7.00	1.00	3.25	1.625	R-38	37	26	60
5	9.50	5.56	12.75	2.88	7.50	7.00	1.00	3.50	1.875	R-42	64	43	104
6	11.00	6.62	14.50	3.25	9.00	8.00	1.00	3.75	2.125	R-47	91	59	147
8	13.38	8.62	17.25	3.88	11.00	8.00	1.00	3.75	2.125	R-51	158	94	249
10	16.75	10.75	21.25	4.62	13.50	9.00	1.50	3.58	2.625	R-55	300	178	476
12	19.50	12.75	24.38	5.25	16.00	9.00	1.50	6.00	2.875	R-60	453	261	714

Groove Dimensions are per ASME B16.5. Gasket Surface Finish & Tolerances per ANSI B16.20

Stocked Materials: 516-Gr70 Carbon Steel and 304 | 316 Stainless Steels (can be manufactured with any material you require)

CUSTOM SIZES AND RATINGS AVAILABLE UPON REQUEST